

Part F 2010 – where to start:

An introduction for house builders and designers

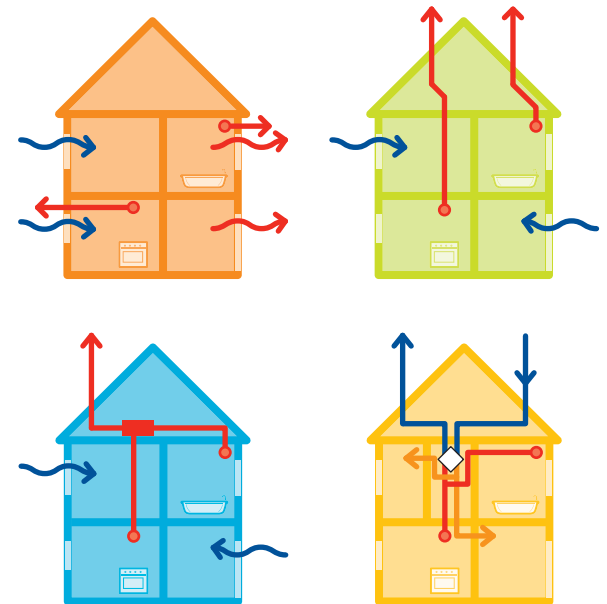

Acknowledgements

This guide was written and published for the NHBC Foundation by Richards Partington Architects.

We particularly wish to acknowledge the contributions of Nick Howlett (Titon), Neil Rideout and Wayne Aston (Passivent), John Palmer (AECOM) and Ian Mawditt (Four Walls).

www.rparchitects.co.uk

copyright © NHBC Foundation 2011

NF 37

ISBN 978-0-9568415-3-7

NHBC Foundation
NHBC House
Davy Avenue
Knowlhill
Milton Keynes
Buckinghamshire MK5 8FP
Tel: 01908 746738
Email: info@nhbcfoundation.org
Web: www.nhbcfoundation.org

supported by:



written and illustrated by:

Richards Partington Architects

Foreword

In recent years the house-building industry has taken significant steps in the delivery of airtight and more energy efficient homes. Homes built to a high level of airtightness will lose less heat through the external construction but reducing infiltration will also remove a source of background ventilation that has previously been relied upon.

Approved Document F has been updated in tandem with the changes to Approved Document L to ensure that good ventilation and indoor air quality is not undermined by changes to achieve energy efficiency. As our industry seeks to achieve the very demanding energy targets set for new dwellings within the next few years we must still remember that the health and comfort of the occupier is paramount.

The 2010 edition of Approved Document F sets out possible strategies that should, if executed correctly, ensure good ventilation regardless of the level of airtightness. This guide will help the smaller house builder decide which strategies are most appropriate for their developments. It follows a similar format to 'Part L – where to start: An introduction for house builders and designers' by working through the possible solutions on a range of common house and apartment types and it, too, aims to cut through and distil the detail of the Approved Document.

The guide is not prescriptive but explains, in simple terms, ways for new homes to comply with the revised Approved Document. The guide also explains some of the terminology in Part F and points the builder and the designer towards the relevant tables and data that must be consulted as well as the requirements for installation and commissioning.

The challenge of the recent and forthcoming changes to the building regulations must not be underestimated and I do hope you find this guide useful. Both the NHBC Foundation and the Zero Carbon Hub are committed to developing further research, information and guidance as we get closer to the goal of zero carbon homes.

Neil Jefferson

Chief Executive,
Zero Carbon Hub



About the NHBC Foundation

The NHBC Foundation was established in 2006 by the NHBC in partnership with the BRE Trust. Its purpose is to deliver high-quality research and practical guidance to help the industry meet its considerable challenges.

Since its inception, the NHBC Foundation's work has focused primarily on the sustainability agenda and the challenges of the Government's 2016 zero carbon homes target. Research has included a review of microgeneration and renewable energy techniques and the groundbreaking research on zero carbon and what it means to homeowners and house builders.

The NHBC Foundation is also involved in a programme of positive engagement with government, development agencies, academics and other key stakeholders, focusing on current and pressing issues relevant to the industry.

Further details on the latest output from the NHBC Foundation can be found at:

www.nhbcfoundation.org.

NHBC Foundation Advisory Board

The work of the NHBC Foundation is guided by the NHBC Foundation Advisory Board, which comprises:

Rt. Hon. Nick Raynsford MP, Chairman

Dr Peter Bonfield, Chief Executive of BRE

Professor John Burland CBE, BRE Trust

Imtiaz Farookhi, Chief Executive of NHBC

Richard Hill, Executive Director, Programmes and Deputy Chief Executive, Homes and Communities Agency

Neil Jefferson, Chief Executive of the Zero Carbon Hub

Rod MacEachrane, NHBC Director (retired)

Robin Nicholson, Senior Partner of Edward Cullinan Architects

Geoff Pearce, Group Director of Development and Asset Management, East Thames Group

David Pretty CBE, Former Chief Executive of Barratt Developments PLC

Professor Steve Wilcox, Centre for Housing Policy, University of York

Contents

Foreword	iii
Introduction	1
Ventilation	2
Key changes from ADF 2006	2
Purpose of the guide	3
How to use the guide	4
Key to the guide	5
Finding information in ADF 2010	6
System 1	7
System 2	13
System 3	19
System 4	25
Purge ventilation	27
What is equivalent area?	28
Window types	29
Ventilator types	30
Home types	31
Looking forward	33
Glossary	34

Introduction

This guide is intended to help house builders and designers understand what the October 2010 changes to **Approved Document F (Ventilation) (ADF)** mean. The latest **ADF** has been updated to take account of the recent increase in the as-built airtightness of buildings. With **Approved Document L1A (ADL1A) 2010** of the building regulations pushing for even lower levels of air permeability, it is important that correct provision is made to allow for controlled ventilation of our living spaces. The changes have also placed a responsibility on the house builder to ensure that mechanical ventilation systems are installed correctly, and where they can be, they are tested and commissioned, and sufficient information on their operation and maintenance is given to occupiers.

As in the previous versions of **ADF**, its focus is the provision of ventilation for providing fresh air for health and well being, control of odour, airborne pollutants and excess humidity. It does not cover the additional ventilation which may be required to control overheating in homes; this is addressed in **ADL1A** of the Building Regulations.

This guide gives examples of some typical homes, outlining a combination of measures needed to comply with **ADF 2010**. The intention is to give a broad understanding of the approaches available for complying with the revised regulations and the practical changes this will entail.

The examples used are based on typical homes on typical developments, from information gathered by NHBC about the homes being built today. The examples are similar to those used in the 'Part L - where to start' guide with the addition of a single aspect apartment which has its own specific requirements for compliance.

This is only a general guide and there is no obligation to adopt any of the specific solutions detailed. You should always check with the Building Control Body (BCB) that your proposals comply with the requirements of the Building Regulations. You will also need to comply with Domestic Ventilation Compliance Guide (DVCG) 2010, NHBC Standards and planning requirements etc.

Ventilation

Ventilation is essential for our health and comfort. We are all aware of the consequences of inadequate ventilation: dampness and mould growth on walls, drowsiness, ill-health and intolerance of allergens for occupiers. In the past ventilation has been provided by a combination of purpose designed devices such as fans, trickle vents and windows and by the invisible but significant quantities of air infiltrating the dwelling through the building fabric.

In older homes the open chimney, sliding sash windows and gaps between floor boards all contributed to the amount of air entering and leaving the dwelling. Openable windows and natural cross-ventilation would also help ensure that a high number of air changes could be achieved without any special ventilation devices. Over time there have been more reasons to introduce specific measures, for instance to avoid condensation or to dilute and remove the combustion gases from heating appliances and boilers. With increased focus on minimising energy losses from buildings especially due to infiltration, strategies for adequate ventilation need to take into account more airtight construction.

The building regulations identify specific ventilation mechanisms that apply to different requirements. There can be a short-term need to remove fumes and smells, from burning toast or painting and decorating. This is generally described as 'purge' ventilation. For certain rooms and activities it is desirable to remove the pollutants or water vapour at source - from the bathroom or kitchen for instance, this may be done by either natural or mechanical means.

A constant amount of 'background' ventilation is also required for each room throughout the day to ensure good air quality and prevent the build-up of pollutants and water vapour from everyday activities such as clothes drying and of course human respiration. In airtight homes this background ventilation has to be controlled: a specific amount of air has to be provided in a secure and draught-free way. It is very important that the background ventilation is not overridden by the occupier, either in the belief that it is causing draughts and wasting money or because the system itself is perceived as being ineffective or too noisy and is turned off as a result.

Key changes from ADF 2006

Key Changes

- Air flow rates need to be measured on site and submitted to BCB
- Higher ventilation rate requirements introduced for dwellings with a fabric air permeability less than $5 \text{ m}^3/(\text{h}\cdot\text{m}^2) @ 50 \text{ Pa}$
- Passive stack diameter increased to 125 mm for all wet rooms
- All fixed mechanical systems need to be commissioned
- Commissioning notice needs to be given to BCB for each installation addressed
- Operation and maintenance manual needs to be provided
- Domestic Ventilation Compliance Guide has been produced to support **ADF 2010**, which includes guidance on design, installation, inspection and testing of natural and mechanical ventilation systems

Additional Guidance

ADF 2010 also offers additional guidance on the following issues:

- Fire and noise control
- Requirements for purge ventilation in habitable and wet rooms
- Background ventilation requirements for single storey dwellings on lower floors (ground to fourth)
- Design criteria for adequate cross-ventilation
- Requirements for air transfer between rooms
- Minimum efficiencies for mechanical systems as given in DVCG
- Routes for obtaining guidance for specific mechanical supply and extract systems
- DVCG installation checklist that must be completed by the builder

Purpose of the guide

There are four approaches that can be taken to providing ventilation, referred to in the ADF as Systems 1–4.

System 1, background ventilators and intermittent extract fans,

is the familiar and commonly used approach where intermittent extract fans are used to remove odour and moisture from wet areas but the general background ventilation to the living spaces is provided through trickle vents around windows or background ventilators in the wall such as air bricks. This system is implemented in the same way as in the previous version of ADF; however, the amount of background ventilation required has been increased significantly. In practice more vents or more efficient ventilators will be required.

System 2, passive stack ventilation (PSV), uses passive ventilators, roof level outlets and background ventilators to achieve air changes through natural buoyancy and wind driven ventilation. In this system air is supplied to the dwelling using background ventilators sized in the same way as System 1.

System 3, continuous mechanical extract (MEV) and System 4, continuous mechanical supply and extract with heat recovery (MVHR), use mechanical systems to distribute air through the dwelling. System 3 discharges it directly to the outside, whilst in System 4 a heat exchanger is used to recover heat from the discharged exhaust air to preheat mechanically supplied fresh air.

Systems 2, 3 and 4 will almost certainly require specialist design input but the builder will need to make a first assessment of the appropriateness of each system before commissioning this specialist work. However, decisions regarding the ventilation strategy are also likely to be influenced by design and specification choices made to achieve reductions in carbon dioxide emissions.

ADF 2010 provides all of the necessary tables and assumptions to allow the designer to calculate the correct ventilation levels, areas of trickle ventilators, and the formulae for working out how much purge ventilation should be provided. There are also two worked examples taking the designer through the steps necessary to demonstrate compliance.

The amount of information that needs to be processed (from different parts of ADF 2010) is quite complicated and the end result is often expressed in terms that will be unfamiliar to many, for instance 'equivalent area'. Ventilation areas in ADF 2010 are consistently given in square millimetres, which will also be an unfamiliar unit and for most not readily grasped. It is not easy to imagine in real terms what an area such as 45,000 mm² represents.

This guide aims to provide the calculations and information necessary to help with specification decisions for common house types. The calculations are ordered by the different ventilation systems, which are colour coded and summarised on one sheet for each house type.

The summary sheet explained on the following page is a 'ready reckoner', giving an overview of the amount of ventilation required and whether it can easily be achieved with a practical arrangement of windows and ventilators. To keep things simple the summary sheet does not repeat information that is common to all of the home types, for instance the individual intermittent extract fan rates for wet rooms and purge ventilation. The provision for purge ventilation to all habitable rooms may be through mechanical extracts or openable windows, whose openable area needs to be calculated based on the internal floor area of each room. This calculation is explained on page 27.

How to use the guide

The guide helps to simplify the calculations by using flow charts to clarify the process outlined in **ADF 2010**. The ready reckoner illustrates what the compliant ventilation requirements mean for actual dwellings with conventional window openings and distribution.

From these charts it will be possible to establish some basic principles and some questions for further discussion with the window and ventilator manufacturers to ensure that a calculated value can actually be delivered for a particular combination of window types and sizes. The first column provides calculations based on the approach for 'any' fabric air permeability value which will ensure adequate ventilation for even the most airtight dwellings.

In the second column requirements are calculated as an alternative which can only be taken if the builder has some certainty about their ability to deliver airtightness consistently leakier than $5 \text{ m}^3/(\text{h}\cdot\text{m}^2) @ 50 \text{ Pa}$.

In order to illustrate these solutions, typical trickle ventilators and windows have been considered. These are detailed on pages 29 and 30.

The ventilation industry produces some very helpful calculators guiding the designer through these processes and recommending particular products. In compiling this guide we have evaluated several of these and found that they give correct results though naturally they tend to direct the designer to the products available from a particular manufacturer.

Step 1

Icon indicates the system type that is being analysed.

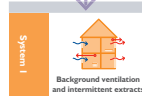

Description
In this mode of providing ventilation, fresh air supply is provided to all habitable rooms through appropriately sized and located trickle ventilators. Extract ventilation is provided through mechanical extract fans located in wet rooms (kitchens, bathrooms and WCs). For dual aspect dwellings, it is best to encourage cross-ventilation; while for single aspect dwellings enhanced single sided ventilation must be used. Guidance is included in **ADF 2010** and specialist advice should be sought.

Ventilation supply
Trickle vents are sized according to the type, location and size of dwelling, using Table 5.2a. **ADF 2010** anticipates that there will be a continued trend towards more airtight dwellings. Through good design and execution, homes can currently achieve an air permeability of between 2 and 4 $\text{m}^3/(\text{h}\cdot\text{m}^2) @ 50 \text{ Pa}$ and as a result trickle ventilator sizes need to be larger than before. For single aspect dwellings, the provision of an equivalent area to achieve the required ventilation rate is to be doubled from the calculated value. It is important to ensure that at sill level, glazed-in/slot vents have the appropriate profile for this location.

Extract ventilation
The extract rates for fans in kitchens, bathrooms and WCs are defined in **ADF 2010**. These rates apply to all dwelling types and sizes. Extract fans need to meet a minimum specific fan power of 0.5 W/l/s as required by the Domestic Building Services Compliance Guide.

- Kitchen (cooker hood) and utility rooms: 30 l/s
- Bathrooms (intermittent extract fans): 15 l/s
- Sanitary accommodation: 6 l/s

Domestic Ventilation Compliance Guide: tables 1 and 2
The installation guidelines do not introduce any unfamiliar advice for the competent builder. However, they usefully point out important considerations for the co-ordination of services with other trades. In particular they identify the need to maintain the integrity of the air barrier where ducts penetrate the external wall and the requirements to seal around the duct penetrations to both the inner and outer leaves for cavity walls. Note also the requirement for insulation to ductwork in unheated spaces. Air flow measurements must be made for intermittent extract fans and flow rates must be recorded.

Part F 2010 – where to start: An introduction for house builders and designers

NHBC FOUNDATION

Any (default) – air permeability ($\text{m}^3/(\text{h}\cdot\text{m}^2) @ 50 \text{ Pa}$)

Leakier than 5 (alternative)

Whole dwelling ventilation requirements

Equivalent Area (EA) of background ventilators required	
55 m^2 / 2 bedroom	45,000 mm^2
Single storey below fifth floor*	+ 10,000 mm^2
	55,000 mm^2
As single aspect dwelling	x 2
Total EA required	110,000 mm^2

Door / Window	no.	EA / window	Total EA
Small square window	2	27,000 mm^2	54,000 mm^2
Large patio door	1	64,000 mm^2	64,000 mm^2
Total EA provided			110,000 mm^2



Whole dwelling ventilation requirements

Equivalent Area (EA) of background ventilators required	
55 m^2 / 2 bedroom	30,000 mm^2
Single storey below fifth floor*	+ 10,000 mm^2
	40,000 mm^2
As single aspect dwelling	x 2
Total EA required	80,000 mm^2

Door / Window	no.	EA / window	Total EA
Small square window	2	27,000 mm^2	54,000 mm^2
Large patio door	1	24,000 mm^2	34,000 mm^2
Total EA provided			88,000 mm^2

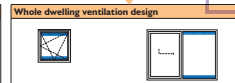

Note: * For single storey dwellings below the fifth floor (ground to fourth) add 10,000 mm^2 to the calculated EA value.

Part F 2010 – where to start: An introduction for house builders and designers

Step 3

Icon indicates the house type being analysed.

Step 4

Alternate calculations for default air permeability of 'any' or alternative air permeability leakier than $5 \text{ m}^3/(\text{h}\cdot\text{m}^2) @ 50 \text{ Pa}$.

Step 5

The equivalent area (EA) of background ventilation that is required by **ADF 2010**.

Step 6

The equivalent area (EA) of background ventilation that can be achieved when particular ventilators and windows are combined.

Key to the guide

Home Types

The guide gives examples of some typical home types on typical developments based on information gathered by the NHBC. These are similar to those used in the 'Part L 2010 - where to start' guide. More detailed information on each home type has been included on pages 31 and 32.

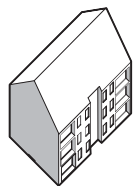

Apartment: single aspect

Each apartment has an internal area of 55 m² with two bedrooms and one bathroom and can accommodate three occupants.

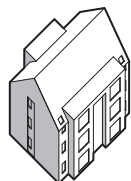

Apartment: dual aspect

Each apartment has an internal area of 58 m² with two bedrooms and one bathroom and can accommodate three occupants.



Mid-terrace house

The terrace house has two storeys with an internal area of 76 m² with three bedrooms, two bathrooms and one WC and can accommodate four occupants.



Detached house

The detached house is 118 m² with four bedrooms and two bathrooms over two storeys. It is suitable for five occupants.



Large detached house

The large detached house is 212 m² over two storeys with five bedrooms and three bathrooms and can accommodate six occupants.

System Types

Four systems are described in the Approved Document. Alternative approaches to compliance are acceptable providing it can be demonstrated they meet the Building Regulation requirement F1 using products or systems that have been certified by a European Technical Approval issuing body such as the BBA.



System 1

Background ventilators and intermittent extract fans.



System 2

Passive stack ventilation (PSV).

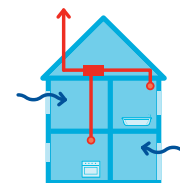

System 3

Continuous mechanical extract (MEV).

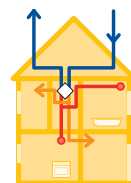

System 4

Continuous mechanical supply and extract with heat recovery (MVHR).

At first sight, Systems 1 and 2 may require onerous requirements for background ventilation, but it may be advisable to seek specialist advice before disregarding a particular strategy solely based on the trickle ventilator area requirement.

Finding information in ADF 2010

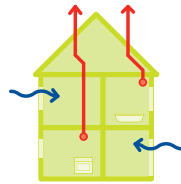
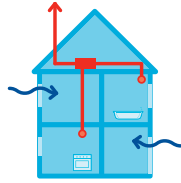
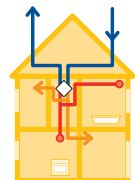
	Extract System	Air Permeability * (m ³ /(h.m ²) @ 50 Pa)	Background Ventilation	Guidance in DVCG **
System 1	 intermittent fans to wet rooms: table 5.1a	<ul style="list-style-type: none"> any (default) >5 (alternative) 	<ul style="list-style-type: none"> background vents: table 5.2a (A) - new provision background vents: table 5.2a (B) - as ADF 2006 	DVCG: tables 1 and 2
System 2	 ductwork: table 5.2b	<ul style="list-style-type: none"> any (default) >5 (alternative) 	<ul style="list-style-type: none"> background vents: table 5.2b (A) - new provision background vents: table 5.2b (B) - as ADF 2006 	DVCG: tables 3 and 4
System 3	 continuously running extract fans	<ul style="list-style-type: none"> any (default) >5 (alternative) 	<ul style="list-style-type: none"> 2,500 mm² background vents per habitable room none required 	DVCG: tables 5 and 6
System 4	 continuously running fans	all	none required - ventilation provided by continuously running fans	DVCG: tables 7 and 8

Notes: * Air permeability is the airtightness of the building fabric, measured as the volume of air leakage per hour per square metre of external building envelope (m³/(h.m²)) at a tested pressure of 50 Pascals.
** The Domestic Ventilation Compliance Guide (DVCG) provides guidance to help comply with Building Regulations for the design, installation, testing and commissioning of ventilation systems.



**Background ventilation
and intermittent extracts**

Description

In this mode of providing ventilation, fresh air supply is provided to all habitable rooms through appropriately sized and located trickle ventilators. Extract ventilation is provided through mechanical extract fans located in wet rooms (kitchens, bathrooms and WCs). For dual aspect dwellings, it is best to encourage cross-ventilation; while for single aspect dwellings enhanced single sided ventilation must be used. Guidance is included in **ADF 2010** and specialist advice should be sought.

Ventilation supply

Trickle vents are sized according to the type, location and size of dwelling, using Table 5.2a. **ADF 2010** anticipates that there will be a continued trend towards more airtight dwellings. Through good design and execution, homes can currently achieve an air permeability of between 2 and 4 m³/(h.m²) @ 50 Pa and as a result trickle ventilator sizes need to be larger than before.

For single aspect dwellings, the provision of an equivalent area to achieve the required ventilation rate is to be doubled from the calculated value. It is important to ensure that at sill level, glazed-in/slot vents have the appropriate profile for this location.

Extract ventilation

The extract rates for fans in kitchens, bathrooms and WCs are defined in **ADF 2010**. These rates apply to all dwelling types and sizes. Extract fans need to meet a minimum specific fan power of 0.5 W/l/s as required by the Domestic Building Services Compliance Guide.

- Kitchen (cooker hood) and utility rooms: 30 l/s
- Bathrooms (intermittent extract fans): 15 l/s
- Sanitary accommodation: 6 l/s

Domestic Ventilation Compliance Guide: tables 1 and 2

The installation guidelines do not introduce any unfamiliar advice for the competent builder. However, they usefully point out important considerations for the co-ordination of services with other trades. In particular they identify the need to maintain the integrity of the air barrier where ducts penetrate the external wall and the requirements to seal around the duct penetrations to both the inner and outer leaves for cavity walls. Note also the requirement for insulation to ductwork in unheated spaces. Air flow measurements must be made for intermittent extract fans and flow rates must be recorded.

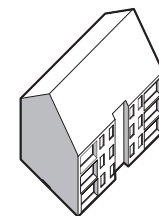

Single aspect apartment

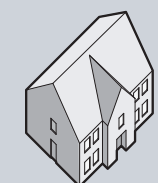
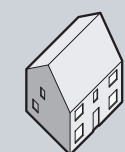
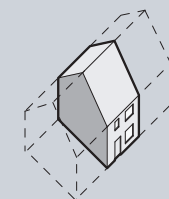
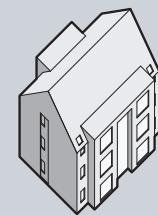

Any (default) — air permeability ($m^3/(h.m^2)$ @ 50 Pa) — Leakier than 5 (alternative)

Whole dwelling ventilation requirements	
Equivalent Area (EA) of background ventilators required:	
55 m ² / 2 bedroom	45,000 mm ²
Single storey below fifth floor *	+ 10,000 mm ²
	55,000 mm ²
As single aspect dwelling	x 2
Total EA required	110,000 mm²

Whole dwelling ventilation requirements	
Equivalent Area (EA) of background ventilators required:	
55 m ² / 2 bedroom	30,000 mm ²
Single storey below fifth floor *	+ 10,000 mm ²
	40,000 mm ²
As single aspect dwelling	x 2
Total EA required	80,000 mm²

Door / Window	no.	EA / window	Total EA
Small square window	2	27,000 mm ²	54,000 mm ²
Large patio door	1	64,000 mm ²	64,000 mm ²
Total EA provided			118,000 mm²

Door / Window	no.	EA / window	Total EA
Small square window	2	27,000 mm ²	54,000 mm ²
Large patio door	1	34,000 mm ²	34,000 mm ²
Total EA provided			88,000 mm²

Whole dwelling ventilation design

Small square window
Ventilator: Glazed-in top & bottom
Ventilators / window: 2
EA / window: 27,000 mm²

Large patio door
Ventilator: Glazed-in top & bottom
Ventilators / window: 4
EA / window: 64,000 mm²

Whole dwelling ventilation design

Small square window
Ventilator: Glazed-in top & bottom
Ventilators / window: 2
EA / window: 27,000 mm²

Large patio door
Ventilator: Glazed-in top & bottom
Ventilators / window: 2
EA / window: 34,000 mm²

Note: * For single storey dwellings below the fifth floor (ground to fourth) add 10,000 mm² to the calculated EA value.

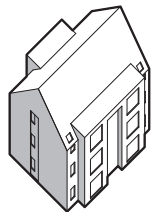
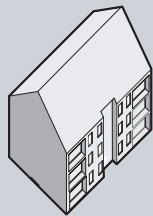

Dual aspect apartment

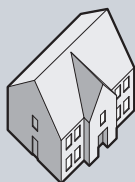
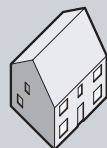

Any (default) — air permeability ($\text{m}^3/(\text{h}\cdot\text{m}^2)$ @ 50 Pa)

Leakier than 5 (alternative)

Whole dwelling ventilation requirements	
Equivalent Area (EA) of background ventilators required:	
58 m ² / 2 bedroom	40,000 mm ²
Single storey below fifth floor *	+ 10,000 mm ²
Total EA required	50,000 mm²

Whole dwelling ventilation requirements	
Equivalent Area (EA) of background ventilators required:	
58 m ² / 2 bedroom	30,000 mm ²
Single storey below fifth floor *	+ 10,000 mm ²
Total EA required	40,000 mm²

Door / Window	no.	EA / window	Total EA
Small single window	2	4,000 mm ²	8,000 mm ²
Small square window	2	13,500 mm ²	27,000 mm ²
Patio door	1	23,000 mm ²	23,000 mm ²
Total EA provided			58,000 mm²

Door / Window	no.	EA / window	Total EA
Small single window	2	4,000 mm ²	8,000 mm ²
Small square window	2	8,000 mm ²	16,000 mm ²
Patio door	1	23,000 mm ²	23,000 mm ²
Total EA provided			47,000 mm²

Whole dwelling ventilation design

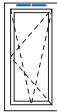
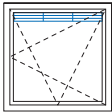
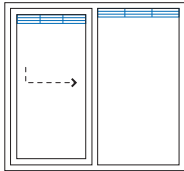
		
Small single window Ventilator: In-frame double Ventilators / window: 1 EA / window: 4,000 mm ²	Small square window Ventilator: Glazed-in top Ventilators / window: 1 EA / window: 13,500 mm ²	Patio door Ventilator: Glazed-in top Ventilators / window: 2 EA / window: 23,000 mm ²

Whole dwelling ventilation design

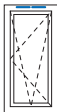
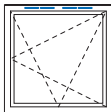
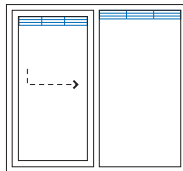
		
Small single window Ventilator: In-frame double Ventilators / window: 1 EA / window: 4,000 mm ²	Small square window Ventilator: In-frame double Ventilators / window: 2 EA / window: 8,000 mm ²	Patio door Ventilator: Glazed-in top Ventilators / window: 2 EA / window: 23,000 mm ²

Note: * For single storey dwellings below the fifth floor (ground to fourth) add 10,000 mm² to the calculated EA value.

Any (default)

air permeability ($m^3/(h.m^2)$ @ 50 Pa)

Leakier than 5 (alternative)

Whole dwelling ventilation requirements	
Equivalent Area (EA) of background ventilators required:	
76 m ² / 3 bedroom	50,000 mm ²
Total EA required	50,000 mm²

Whole dwelling ventilation requirements	
Equivalent Area (EA) of background ventilators required:	
76 m ² / 3 bedroom	35,000 mm ²
Total EA required	35,000 mm²

Door / Window	no.	EA / window	Total EA
Small single window	1	2,500 mm ²	2,500 mm ²
Small square window	5	8,000 mm ²	40,000 mm ²
Full height window	1	11,500 mm ²	11,500 mm ²
Total EA provided			54,000 mm²

Door / Window	no.	EA / window	Total EA
Small single window	1	2,500 mm ²	2,500 mm ²
Small square window	5	5,000 mm ²	25,000 mm ²
Full height window	1	8,000 mm ²	8,000 mm ²
Total EA provided			35,500 mm²

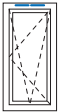
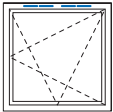
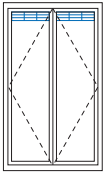
Whole dwelling ventilation design		
		
Small single window Ventilator: In-frame single Ventilators / window: 1 EA / window: 2,500 mm ²	Small square window Ventilator: In-frame double Ventilators / window: 2 EA / window: 8,000 mm ²	Full height window Ventilator: Glazed-in top Ventilators / window: 2 EA / window: 11,500 mm ²

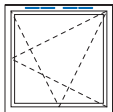
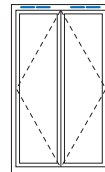
Whole dwelling ventilation design		
		
Small single window Ventilator: In-frame single Ventilators / window: 1 EA / window: 2,500 mm ²	Small square window Ventilator: In-frame single Ventilators / window: 2 EA / window: 5,000 mm ²	Full height window Ventilator: In-frame double Ventilators / window: 2 EA / window: 8,000 mm ²

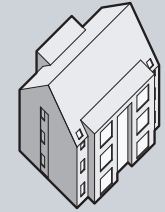
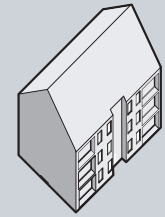

Mid-terrace house

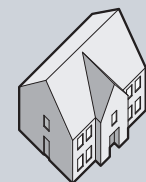
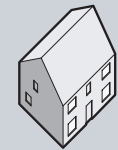

System 1

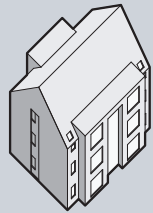
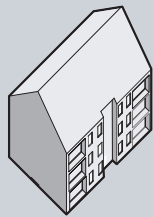

Any (default) — air permeability ($\text{m}^3/(\text{h} \cdot \text{m}^2)$ @ 50 Pa)

Leakier than 5 (alternative)

Whole dwelling ventilation requirements	
Equivalent Area (EA) of background ventilators required:	
118 m ² / 4 bedroom	65,000 mm ²
18 m ² above ADF 2010 threshold *	+ 14,000 mm ²
Total EA required	79,000 mm²

Whole dwelling ventilation requirements	
Equivalent Area (EA) of background ventilators required:	
118 m ² / 4 bedroom	45,000 mm ²
18 m ² above ADF 2010 threshold *	+ 10,000 mm ²
Total EA required	55,000 mm²

Door / Window	no.	EA / window	Total EA
Small single window	5	2,500 mm ²	12,500 mm ²
Small square window	6	4,000 mm ²	24,000 mm ²
Patio door	4	12,000 mm ²	48,000 mm ²
Total EA provided			84,500 mm²

Door / Window	no.	EA / window	Total EA
Small single window	5	2,500 mm ²	12,500 mm ²
Small square window	6	2,500 mm ²	15,000 mm ²
Patio door	4	8,000 mm ²	32,000 mm ²
Total EA provided			59,500 mm²

Whole dwelling ventilation design

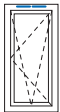
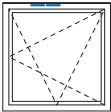
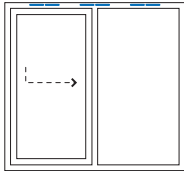
		
Small single window Ventilator: In-frame single Ventilators / window: 1 EA / window: 2,500 mm ²	Small square window Ventilator: In-frame double Ventilators / window: 1 EA / window: 4,000 mm ²	Patio door Ventilator: In-frame double Ventilators / window: 3 EA / window: 12,000 mm ²

Whole dwelling ventilation design

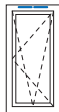
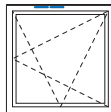
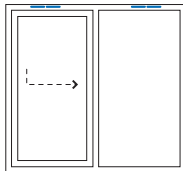
		
Small single window Ventilator: In-frame single Ventilators / window: 1 EA / window: 2,500 mm ²	Small square window Ventilator: In-frame single Ventilators / window: 1 EA / window: 2,500 mm ²	Patio door Ventilator: In-frame double Ventilators / window: 2 EA / window: 8,000 mm ²

Note: * For dwellings with a floor area greater than 100 m² and any air permeability add 7,000 mm² for every additional 10 m² floor area. For dwellings with a floor area greater than 100 m² and an air permeability leakier than 5 m³/(h.m²) @ 50 Pa add 5,000 mm² for every additional 10 m² floor area.

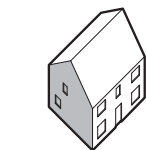

Detached house

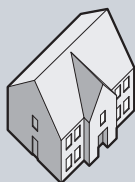

Any (default)

air permeability ($m^3/(h.m^2)$ @ 50 Pa)

Leakier than 5 (alternative)

Whole dwelling ventilation requirements	
Equivalent Area (EA) of background ventilators required:	
212 m ² / 5 bedroom	65,000 mm ²
112 m ² over ADF 2010 threshold *	+ 84,000 mm ²
Total EA required	149,000 mm²

Whole dwelling ventilation requirements	
Equivalent Area (EA) of background ventilators required:	
212 m ² / 5 bedroom	55,000 mm ²
112 m ² over ADF 2010 threshold *	+ 60,000 mm ²
Total EA required	115,000 mm²

Door / Window	no.	EA / window	Total EA
Small single window	1	2,500 mm ²	2,500 mm ²
Small square window	17	8,000 mm ²	136,000 mm ²
Patio door	2	8,000 mm ²	16,000 mm ²
Total EA provided			154,500 mm²

Door / Window	no.	EA / window	Total EA
Small single window	1	2,500 mm ²	2,500 mm ²
Small square window	17	5,000 mm ²	85,000 mm ²
Patio door	2	23,000 mm ²	46,000 mm ²
Total EA provided			133,500 mm²

Whole dwelling ventilation design

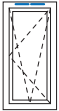

Small single window
Ventilator: In-frame single
Ventilators / window: 1
EA / window: 2,500 mm²

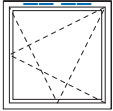

Small square window
Ventilator: In-frame double
Ventilators / window: 2
EA / window: 8,000 mm²

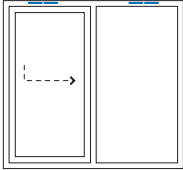

Patio door
Ventilator: In-frame double
Ventilators / window: 2
EA / window: 8,000 mm²

Whole dwelling ventilation design



Small single window
Ventilator: In-frame single
Ventilators / window: 1
EA / window: 2,500 mm²

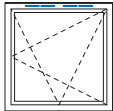

Small square window
Ventilator: In-frame single
Ventilators / window: 2
EA / window: 5,000 mm²

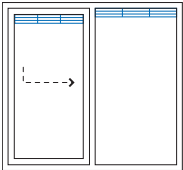

Patio door
Ventilator: Glazed-in top
Ventilators / window: 2
EA / window: 23,000 mm²

Note: * For dwellings with a floor area greater than 100 m² and any air permeability add 7,000 mm² for every additional 10 m² floor area. For dwellings with a floor area greater than 100 m² and an air permeability leakier than 5 m³/(h.m²) @ 50 Pa add 5,000 mm² for every additional 10 m² floor area.

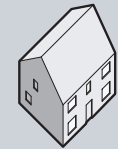
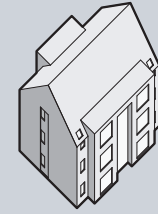
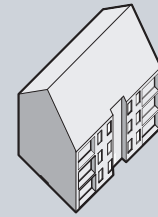

Large detached house

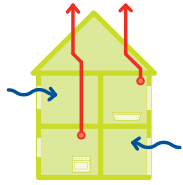

Passive stack ventilation (PSV)

Description

In passive stack ventilation, fresh air is drawn into all habitable rooms through appropriately sized and located background ventilators. Extract ventilation is driven by the stack effect and wind, and is provided through vertical ductwork from all wet rooms (bathrooms, WCs and kitchens). There are no mechanical components used for the provision of background ventilation in this system. However, the design should take into account the location of the dwelling and surrounding buildings. For this system, specialist advice should be sought.

Ventilation supply

As in System 1, trickle vents are sized according to the type, location and size of dwelling, using Table 5.2b. **ADF 2010** anticipates that there will be a continued trend towards more airtight dwellings. Through good design and execution, homes can currently achieve an air permeability of between 2 and 4 m³/(h.m²) @ 50 Pa and as a result trickle ventilator sizes need to be larger than before.

Extract ventilation

All extract vents are to be sized to have an internal cross-sectional area of 12,000 mm² and a minimum internal duct diameter of 125 mm.

Domestic Ventilation Compliance Guide: tables 3 and 4

The guidance is straightforward and relatively brief - inspections at the end of the installation are all visual. The effectiveness of the system will depend on the careful planning of duct routes through the dwelling and the correct positioning of ductwork and extract terminals. It is important to achieve near vertical ductwork routes with a minimum number of bends (see diagrams 2 and 3 of the DVCG). While it is noted that flexible ductwork is acceptable it is stressed that adequate support is needed to prevent sagging. Also ductwork extending outside the dwelling must be rigid.

The same points regarding the penetration of the air barrier and unheated spaces are made and it is advisable to ensure that the ductwork route is co-ordinated on design plans and sections. A full design service is usually provided by manufacturers.

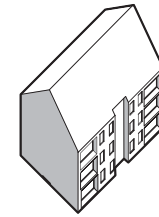

Single aspect apartment

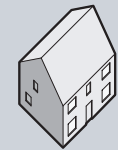
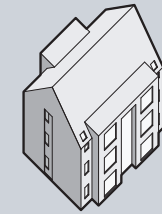

Any (default) — air permeability ($\text{m}^3/(\text{h}\cdot\text{m}^2)$ @ 50 Pa)

Leakier than 5 (alternative)

Whole Dwelling Ventilation Requirements

Equivalent Area (EA) of background ventilators required:

55 m ² / 2 bedroom	40,000 mm ²
Single storey below fifth floor *	+ 10,000 mm ²
EA allowance for PSV	- 6,000 mm ²
	44,000 mm ²
or total PSV cross-sectional area	24,000 mm ²
Total EA required	44,000 mm²

Whole Dwelling Ventilation Requirements

Equivalent Area (EA) of background ventilators required:

55 m ² / 2 bedroom	30,000 mm ²
Single storey below fifth floor *	+ 10,000 mm ²
EA allowance for PSV	- 6,000 mm ²
	34,000 mm ²
or total PSV cross-sectional area	24,000 mm ²
Total EA required	34,000 mm²

Door / Window	no.	EA / window	Total EA
Small square window	2	8,000 mm ²	16,000 mm ²
Large patio door	1	32,000 mm ²	32,000 mm ²
Total EA provided			48,000 mm²

Door / Window	no.	EA / window	Total EA
Small square window	2	2,500 mm ²	5,000 mm ²
Large patio door	1	32,000 mm ²	32,000 mm ²
Total EA provided			37,000 mm²

Whole dwelling ventilation design

Small square window
Ventilator: In-frame double
Ventilators per window: 2
EA/window: 8,000 mm²

Large patio door
Ventilator: Glazed-in top
Ventilators per window: 2
EA/window: 32,000 mm²

Whole dwelling ventilation design

Small square window
Ventilator: In-frame single
Ventilators per window: 1
EA/window: 2,500 mm²

Large patio door
Ventilator: Glazed-in top
Ventilators per window: 2
EA/window: 32,000 mm²

Note: * For single storey dwellings below the fifth floor (ground to fourth) add 10,000 mm² to the calculated EA value.

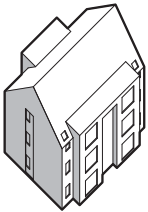
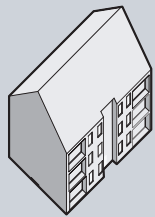

Dual aspect apartment

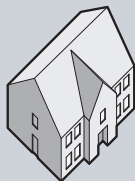

Any (default) — air permeability ($\text{m}^3/(\text{h}\cdot\text{m}^2)$ @ 50 Pa)

Leakier than 5 (alternative)

Whole Dwelling Ventilation Requirements

Equivalent Area (EA) of background ventilators required:

58 m ² / 2 bedroom	40,000 mm ²
Single storey below fifth floor *	+ 10,000 mm ²
EA allowance for PSV	– 6,000 mm ²
	44,000 mm ²
or total PSV cross-sectional area	24,000 mm ²
Total EA required	44,000 mm²

Whole Dwelling Ventilation Requirements

Equivalent Area (EA) of background ventilators required:

58 m ² / 2 bedroom	30,000 mm ²
Single storey below fifth floor *	+ 10,000 mm ²
EA allowance for PSV	– 6,000 mm ²
	34,000 mm ²
or total PSV cross-sectional area	24,000 mm ²
Total EA required	34,000 mm²

Door / Window	no.	EA / window	Total EA
Small single window	0	0 mm ²	0 mm ²
Small square window	2	13,500 mm ²	27,000 mm ²
Patio door	1	23,000 mm ²	23,000 mm ²
Total EA provided			50,000 mm²

Door / Window	no.	EA / window	Total EA
Small single window	1	4,000 mm ²	4,000 mm ²
Small square window	2	4,000 mm ²	8,000 mm ²
Patio door	1	23,000 mm ²	23,000 mm ²
Total EA provided			35,000 mm²

Whole dwelling ventilation design

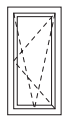

Small single window
Ventilator: None
Ventilators / window: 0
EA / window: 0 mm²

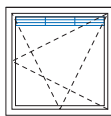

Small square window
Ventilator: Glazed-in top
Ventilators / window: 1
EA / window: 13,500 mm²

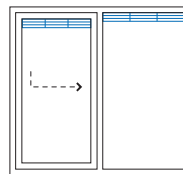

Patio door
Ventilator: Glazed-in top
Ventilators / window: 2
EA / window: 23,000 mm²

Whole dwelling ventilation design

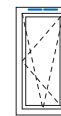

Small single window
Ventilator: In-frame double
Ventilators / window: 1
EA / window: 4,000 mm²

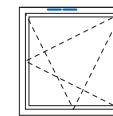

Small square window
Ventilator: In-frame double
Ventilators / window: 1
EA / window: 4,000 mm²

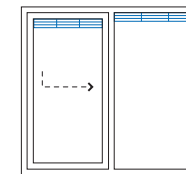

Patio door
Ventilator: Glazed-in top
Ventilators / window: 2
EA / window: 23,000 mm²

Note: * For single storey dwellings below the fifth floor (ground to fourth) add 10,000 mm² to the calculated EA value.

Any (default)

air permeability ($\text{m}^3/(\text{h}\cdot\text{m}^2)$ @ 50 Pa)

Leakier than 5 (alternative)

Whole Dwelling Ventilation Requirements	
Equivalent Area (EA) of background ventilators required:	
76 m ² / 3 bedroom	40,000 mm ²
Within ADF 2010 area threshold	+ 0 mm ²
EA allowance for PSV	- 12,000 mm ²
	28,000 mm ²
or total PSV cross-sectional area	48,000 mm ²
Total EA required	48,000 mm²

Whole Dwelling Ventilation Requirements	
Equivalent Area (EA) of background ventilators required:	
76 m ² / 3 bedroom	35,000 mm ²
Within ADF 2010 area threshold	+ 0 mm ²
EA allowance for PSV	- 12,000 mm ²
	23,000 mm ²
or total PSV cross-sectional area	48,000 mm ²
Total EA required	48,000 mm²

Door / Window	no.	EA / window	Total EA
Small single window	0	0 mm ²	0 mm ²
Small square window	4	13,500 mm ²	54,000 mm ²
Full height window	1	2,500 mm ²	2,500 mm ²
Total EA provided			56,500 mm²

Door / Window	no.	EA / window	Total EA
Small single window	0	0 mm ²	0 mm ²
Small square window	4	13,500 mm ²	54,000 mm ²
Full height window	1	2,500 mm ²	2,500 mm ²
Total EA provided			56,500 mm²

Whole dwelling ventilation design

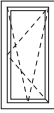

Small single window
Ventilator: None
Ventilators / window: 0
EA / window: 0 mm²

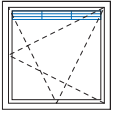

Small square window
Ventilator: Glazed-in top
Ventilators / window: 1
EA / window: 13,500 mm²

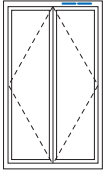

Full height window
Ventilator: In-frame single
Ventilators / window: 1
EA / window: 2,500 mm²

Whole dwelling ventilation design

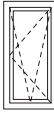

Small single window
Ventilator: None
Ventilators / window: 0
EA / window: 0 mm²

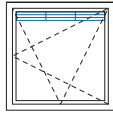

Small square window
Ventilator: Glazed-in top
Ventilators / window: 1
EA / window: 13,500 mm²

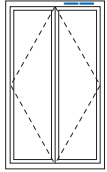

Full height window
Ventilator: In-frame single
Ventilators / window: 1
EA / window: 2,500 mm²

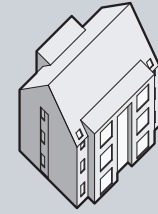
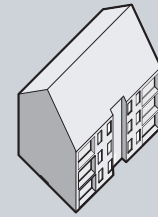

Mid-terrace house

System 2

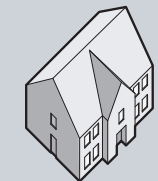
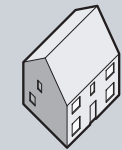

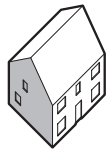
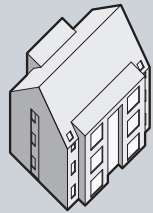
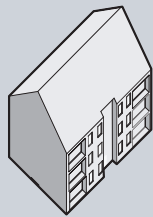

Detached house

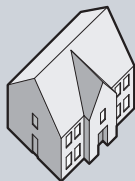

Any (default)

air permeability ($\text{m}^3/(\text{h}\cdot\text{m}^2)$ @ 50 Pa)

Leakier than 5 (alternative)

Whole Dwelling Ventilation Requirements

Equivalent Area (EA) of background ventilators required:

118 m ² / 4 bedroom	65,000 mm ²
18 m ² above ADF 2010 area threshold *	+ 14,000 mm ²
EA allowance for PSV	- 15,000 mm ²
	64,000 mm ²
or total PSV cross-sectional area	60,000 mm ²
Total EA required	64,000 mm²

Whole Dwelling Ventilation Requirements

Equivalent Area (EA) of background ventilators required:

118 m ² / 4 bedroom	45,000 mm ²
18 m ² above ADF 2010 area threshold *	+ 10,000 mm ²
EA allowance for PSV	- 15,000 mm ²
	40,000 mm ²
or total PSV cross-sectional area	60,000 mm ²
Total EA required	60,000 mm²

Door / Window	no.	EA / window	Total EA
Small single window	2	2,500 mm ²	5,000 mm ²
Small square window	5	8,000 mm ²	40,000 mm ²
Patio door	3	8,000 mm ²	24,000 mm ²
Total EA provided			69,000 mm²

Door / Window	no.	EA / window	Total EA
Small single window	2	2,500 mm ²	5,000 mm ²
Small square window	5	8,000 mm ²	40,000 mm ²
Patio door	3	5,000 mm ²	15,000 mm ²
Total EA provided			60,000 mm²

Whole dwelling ventilation design

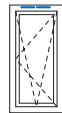

Small single window
Ventilator: In-frame single
Ventilators / window: 1
EA / window: 2,500 mm²

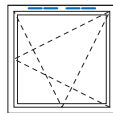

Small square window
Ventilator: In-frame double
Ventilators / window: 2
EA / window: 8,000 mm²

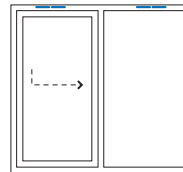

Patio door
Ventilator: In-frame double
Ventilators / window: 2
EA / window: 8,000 mm²

Whole dwelling ventilation design



Small single window
Ventilator: In-frame single
Ventilators / window: 1
EA / window: 2,500 mm²

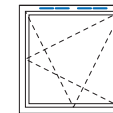

Small square window
Ventilator: In-frame double
Ventilators / window: 2
EA / window: 8,000 mm²

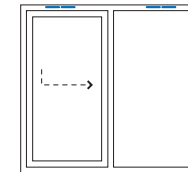

Patio door
Ventilator: In-frame single
Ventilators / window: 2
EA / window: 5,000 mm²

Note: * For dwellings with a floor area greater than 100 m² and any air permeability add 7,000 mm² for every additional 10 m² floor area. For dwellings with a floor area greater than 100 m² and an air permeability leakier than 5 m³/(h.m²) @ 50 Pa add 5,000 mm² for every additional 10 m² floor area.

Any (default)

air permeability ($m^3/(h.m^2)$ @ 50 Pa)

Leakier than 5 (alternative)

Whole Dwelling Ventilation Requirements

Equivalent Area (EA) of background ventilators required:	
212 m ² / 5 bedroom	65,000 mm ²
112 m ² over ADF 2010 area threshold *	+ 84,000 mm ²
EA allowance for PSV	- 18,000 mm ²
	131,000 mm ²
or total PSV cross-sectional area	72,000 mm ²
Total EA required	131,000 mm²

Whole Dwelling Ventilation Requirements

Equivalent Area (EA) of background ventilators required:	
212 m ² / 5 bedroom	55,000 mm ²
112 m ² over ADF 2010 area threshold *	+ 60,000 mm ²
EA allowance for PSV	- 18,000 mm ²
	97,000 mm ²
or total PSV cross-sectional area	72,000 mm ²
Total EA required	97,000 mm²

Door / Window	no.	EA / window	Total EA
Small single window	1	4,000 mm ²	4,000 mm ²
Small square window	14	8,000 mm ²	112,000 mm ²
Patio door	2	8,000 mm ²	16,000 mm ²
Total EA provided			132,000 mm²

Door / Window	no.	EA / window	Total EA
Small single window	1	4,000 mm ²	4,000 mm ²
Small square window	14	5,000 mm ²	70,000 mm ²
Patio door	2	12,000 mm ²	24,000 mm ²
Total EA provided			98,000 mm²

Whole dwelling ventilation design

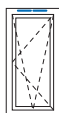

Small single window
Ventilator: In-frame double
Ventilators / window: 1
EA / window: 4,000 mm²

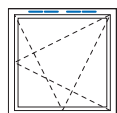

Small square window
Ventilator: In-frame double
Ventilators / window: 2
EA / window: 8,000 mm²

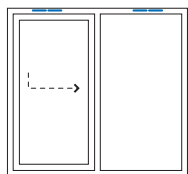

Patio door
Ventilator: In-frame double
Ventilators / window: 2
EA / window: 8,000 mm²

Whole dwelling ventilation design

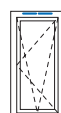

Small single window
Ventilator: In-frame double
Ventilators / window: 1
EA / window: 4,000 mm²

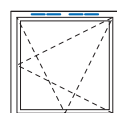

Small square window
Ventilator: In-frame single
Ventilators / window: 2
EA / window: 5,000 mm²

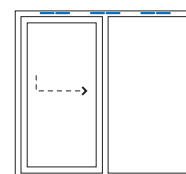

Patio door
Ventilator: In-frame double
Ventilators / window: 3
EA / window: 12,000 mm²

Note: * For dwellings with a floor area greater than 100 m² and any air permeability add 7,000 mm² for every additional 10 m² floor area. For dwellings with a floor area greater than 100 m² and an air permeability leakier than 5 m³/(h.m²) @ 50 Pa add 5,000 mm² for every additional 10 m² floor area.

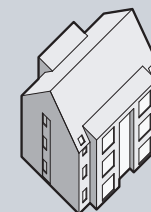
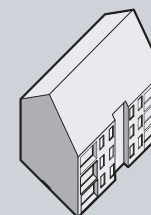

Large detached house

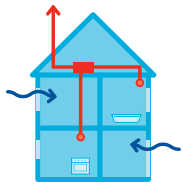

Continuous mechanical extract (MEV)

Description

This system uses continuously running extract fans that create a negative pressure within the dwelling drawing in fresh air through vents and openings. Extract fans are installed to all wet rooms and must incorporate a boost function to temporarily increase the rate of extract as needed to dispel moisture, odour etc.

Ventilation supply

All habitable rooms are provided with trickle vents with an equivalent area of 2,500 mm². These vents may be omitted where buildings have been designed and measured to have an air permeability leakier than 5 m³/(h.m²) @ 50 Pa as it can be assumed adequate fresh air will be drawn through the building fabric. However, greater heat loss due to infiltration needs to be accounted for in the strategy devised to meet ADL1A requirements.

Extract ventilation

All wet rooms require extract fans, the rates for which are defined in Tables 5.1a and 5.1b. The whole dwelling ventilation rate (i.e. normal rate) is determined according to the number of bedrooms or by the floor area of the dwelling, whichever is greater. The whole dwelling extract ventilation rate (i.e. boost rate) is based on the number of wet rooms.

Extract fans need to have a minimum specific fan power of 0.7 W/l/s as required by the Domestic Building Services Compliance Guide.

Domestic Ventilation Compliance Guide: tables 5 and 6

The installation clauses provide advice regarding the positioning and termination of ductwork and its relationship with other tasks. A fundamental point to address is the location of the fan unit and the optimisation of duct routes in relation to the internal extract terminals and the external discharge point. Locating the unit in an uninsulated loft space may be convenient but provisions will need to be made for insulating both the unit and the connecting ductwork to prevent condensation.

Ductwork should be rigid as far as possible with condensate traps for vertical installations. As it is an extract-only system filters do not have to be installed, but access for cleaning and maintenance needs to be provided.

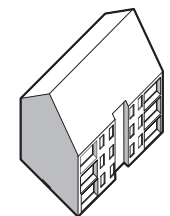

Single aspect apartment

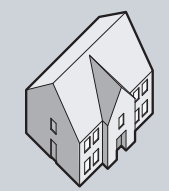
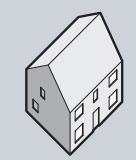
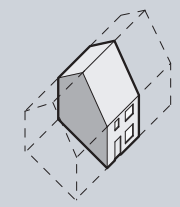
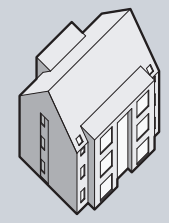

Extract Ventilation Requirements for System 3: MEV
 Maximum whole dwelling extract rate (boost rate): 21.0 l/s
 Minimum whole dwelling extract rate (normal rate): 17.0 l/s

Any (default) — air permeability (m³/(h.m²) @ 50 Pa) — Leakier than 5 (alternative)

Whole Dwelling Ventilation Requirements

Equivalent Area (EA) of background ventilators required:

EA / habitable room	2,500 mm ²
No. of habitable rooms	x 3
Total EA required	7,500 mm²

Whole Dwelling Ventilation Requirements

Equivalent Area (EA) of background ventilators required:

	None
--	-------------

Door / Window	no.	EA / window	Total EA
Small square window	2	2,500 mm ²	5,000 mm ²
Large patio door	1	2,500 mm ²	2,500 mm ²
Total EA provided			7,500 mm²

Whole dwelling ventilation design

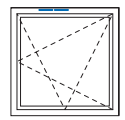

Small square window
 Ventilator: In-frame single
 Ventilators / window: 1
 EA/window: 2,500 mm²

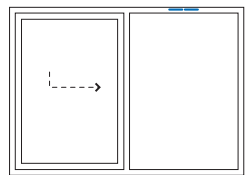

Large patio door
 Ventilator: In-frame single
 Ventilators / window: 1
 EA/window: 2,500 mm²

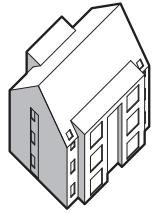
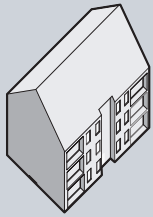

Dual aspect apartment



Extract Ventilation Requirements for System 3: MEV

Maximum whole dwelling extract rate (boost rate): 21.0 l/s
 Minimum whole dwelling extract rate (normal rate): 17.4 l/s

Any (default) — air permeability ($\text{m}^3/(\text{h.m}^2)$ @ 50 Pa) — Leakier than 5 (alternative)

Whole Dwelling Ventilation Requirements

Equivalent Area (EA) of background ventilators required:

EA / habitable room	2,500 mm ²
No. of habitable rooms	x 3
Total EA required	7,500 mm²

Whole Dwelling Ventilation Requirements

Equivalent Area (EA) of background ventilators required:

None

Door / Window	no.	EA / window	Total EA
Small single window	0	0 mm ²	0 mm ²
Small square window	2	2,500 mm ²	5,000 mm ²
Patio door	1	2,500 mm ²	2,500 mm ²
Total EA provided			7,500 mm²

Whole dwelling ventilation design

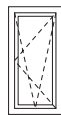

Small single window
 Ventilator: None
 Ventilators / window: 0
 EA / window: 0 mm²

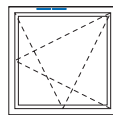

Small square window
 Ventilator: In-frame single
 Ventilators / window: 1
 EA / window: 2,500 mm²

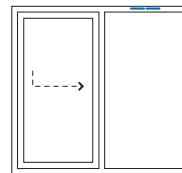

Patio door
 Ventilator: In-frame single
 Ventilators / window: 1
 EA / window: 2,500 mm²

Extract Ventilation Requirements for System 3: MEV

Maximum whole dwelling extract rate (boost rate): 35.0 l/s
 Minimum whole dwelling extract rate (normal rate): 22.8 l/s

Any (default) — air permeability ($\text{m}^3/(\text{h}\cdot\text{m}^2)$ @ 50 Pa) — Leakier than 5 (alternative)

Whole Dwelling Ventilation Requirements

Equivalent Area (EA) of background ventilators required:

EA / habitable room	2,500 mm ²
No. of habitable rooms	x 5
Total EA required	12,500 mm²

Whole Dwelling Ventilation Requirements

Equivalent Area (EA) of background ventilators required:

	None
--	-------------

Door/Window	no.	EA/window	Total EA
Small single window	0	0 mm ²	0 mm ²
Small square window	4	2,500 mm ²	10,000 mm ²
Full height window	1	2,500 mm ²	2,500 mm ²
Total EA provided			12,500 mm²

Whole dwelling ventilation design

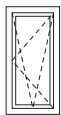

Small single window
 Ventilator: None
 Ventilators / window: 0
 EA / window: 0 mm²

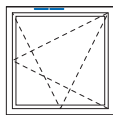

Small square window
 Ventilator: In-frame single
 Ventilators / window: 1
 EA / window: 2,500 mm²

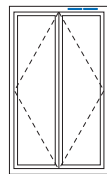

Full height window
 Ventilator: In-frame single
 Ventilators / window: 1
 EA / window: 2,500 mm²

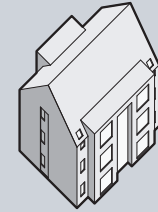
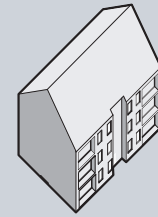

Mid-terrace house

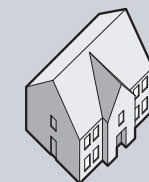

System 3

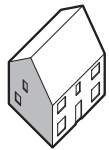
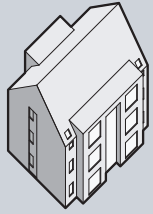
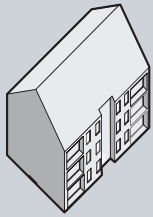

Detached house



Extract Ventilation Requirements for System 3: MEV

Maximum whole dwelling extract rate (boost rate): 43.0 l/s
 Minimum whole dwelling extract rate (normal rate): 35.4 l/s

Any (default) — air permeability ($\text{m}^3/(\text{h}\cdot\text{m}^2)$ @ 50 Pa) — Leakier than 5 (alternative)

Whole Dwelling Ventilation Requirements

Equivalent Area (EA) of background ventilators required:

EA / habitable room	2,500 mm ²
No. of habitable rooms	x 7
Total EA required	17,500 mm²

Whole Dwelling Ventilation Requirements

Equivalent Area (EA) of background ventilators required:

None

Door/Window	no.	EA/window	Total EA
Small single window	0	0 mm ²	0 mm ²
Small square window	4	2,500 mm ²	10,000 mm ²
Patio door	3	2,500 mm ²	7,500 mm ²
Total EA provided			17,500 mm²

Whole dwelling ventilation design

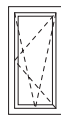

Small single window
 Ventilator: None
 Ventilators / window: 0
 EA / window: 0 mm²

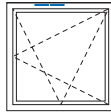

Small square window
 Ventilator: In-frame single
 Ventilators / window: 1
 EA / window: 2,500 mm²

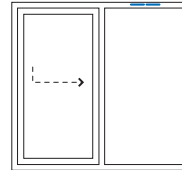

Patio door
 Ventilator: In-frame single
 Ventilators / window: 1
 EA / window: 2,500 mm²

Extract Ventilation Requirements for System 3: MEV

Maximum whole dwelling extract rate (boost rate): 63.6 l/s
 Minimum whole dwelling extract rate (normal rate): 51.0 l/s

Any (default) — air permeability ($\text{m}^3/(\text{h}\cdot\text{m}^2)$ @ 50 Pa) — Leakier than 5 (alternative)

Whole Dwelling Ventilation Requirements

Equivalent Area (EA) of background ventilators required:

EA / habitable room	2,500 mm ²
No. of habitable rooms	x 9
Total EA required	22,500 mm²

Whole Dwelling Ventilation Requirements

Equivalent Area (EA) of background ventilators required:

	None
--	-------------

Door/Window	no.	EA/window	Total EA
Small single window	0	0 mm ²	0 mm ²
Small square window	7	2,500 mm ²	17,500 mm ²
Patio door	2	2,500 mm ²	5,000 mm ²
Total EA provided		22,500 mm²	

Whole dwelling ventilation design

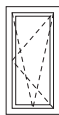

Small single window
 Ventilator: None
 Ventilators / window: 0
 EA / window: 0 mm²

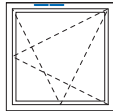

Small square window
 Ventilator: In-frame single
 Ventilators / window: 1
 EA / window: 2,500 mm²

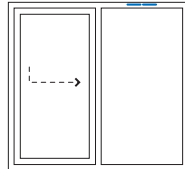

Patio door
 Ventilator: In-frame single
 Ventilators / window: 1
 EA / window: 2,500 mm²

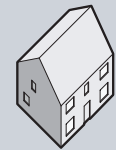
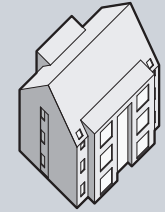
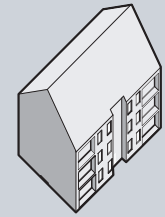

Large detached house

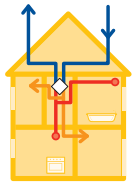

Continuous mechanical supply and extract (MVHR)

Description

This is a balanced whole house ventilation strategy where stale air is removed from wet rooms at a constant rate and fresh air is supplied to all habitable rooms mechanically. In the ventilation unit, heat is removed from the warm extract air via a heat exchanger and is used to pre-heat the incoming supply air, thereby reducing heat loss due to ventilation.

Ventilation supply

Supply air diffusers are located in all habitable spaces. In theory, MVHR can be installed in a building where the fabric is leakier than $5 \text{ m}^3/(\text{h}\cdot\text{m}^2) @ 50 \text{ Pa}$. However, for the heat recovery to be effective the MVHR unit should be installed in an airtight dwelling.

Extract ventilation

Extract points are to be installed at least in all wet rooms. ADF states the minimum extract rates for individual wet rooms under boost operation. The extract rates for normal operation are determined by balancing the system through commissioning to achieve the whole dwelling supply rate.

The MVHR unit needs to meet a minimum system efficiency of 1.5 W/l/s and the minimum heat exchanger efficiency of 70% as required by the Domestic Building Services Compliance Guide.

Domestic Ventilation Compliance Guide: tables 7 and 8

In addition to general guidance on the positioning, installation, sealing and termination of ductwork, the guide stresses the importance of providing proper drainage for the condensate from the heat recovery unit.

All the installed ductwork should be rigid as far as possible with minimal runs of flexible sections. The heat recovery unit should be located in a heated space or an insulated space where this is not possible. Access for maintenance and cleaning should also be considered when locating the unit. The supply and extract terminals need to be specified and installed correctly.

As this type of ventilation depends on mechanical systems both for supplying and extracting air, it is important that the user controls that are provided do not allow the units to be switched off easily (i.e. only for maintenance and repair). Controls for boost operation, however, need to be provided at a convenient location. Where an override function such as summer bypass is included the operation and control should be well explained in the home user guide.

Calculations using ADF

ADF 2010 uses a series of calculations to determine the extract and supply rates for System 4.

Step 1 - whole dwelling supply rate. This is calculated using Table 5.1 b, and is based on either the number of bedrooms or floor area of the dwelling, whichever is larger. With the exception of small dwellings, it is likely that the whole dwelling ventilation rate will be based on the floor area.

For dwellings with an air permeability leakier than 5 m³/(h.m²) @ 50 Pa, infiltration is taken into account and a reduced whole dwelling supply rate is possible.

Step 2 - whole dwelling extract rate. This is calculated based on the number of wet rooms (Table 5.1 a). ADF specifies the minimum extract rates for individual wet rooms that need to be achieved in 'boost' mode.

Step 3 - required air flow rates. The maximum whole dwelling extract ventilation rate (i.e. boost rate) should be at least the greater of Step 1 and Step 2.

In general the ventilation system should balance the air supply and air extract rate, in both normal and boost modes.

In some cases, for instance in very large dwellings, the 'boost' extract rate based on the number of wet rooms in Step 2 (Table 5.1 a) may be lower than the whole dwelling supply rate calculated on the basis of the floor area in Step 1. Adjustments may be made to the extract rates at individual extract terminals or to the number of extract terminals. In such instances specialist input should be sought.

The designer should ensure that the correct ventilation rate is set at the terminal points taking into account noise and the effects of increased air velocities.

Supply and extract requirements for System 4: MVHR		Single aspect apartment	Dual aspect apartment	Mid-terrace house	Detached house	Large detached house
Step 1	Whole dwelling supply rate: by bedrooms (Table 5.1 b)	17.0 l/s	17.0 l/s	21.0 l/s	25.0 l/s	29.0 l/s
	Whole dwelling supply rate: by floor area (Table 5.1 b)	16.5 l/s	17.4 l/s	22.8 l/s	35.4 l/s	63.6 l/s
	Whole dwelling supply rate for dwellings leakier than 5	10.7 l/s	10.8 l/s	15.0 l/s	23.4 l/s	42.0 l/s
Step 2	Whole dwelling extract rate: by wet rooms (Table 5.1 a)	21.0 l/s	21.0 l/s	35.0 l/s	43.0 l/s	51.0 l/s
Step 3	Minimum high rate (boost rate)	21.0 l/s	21.0 l/s	35.0 l/s	43.0 l/s	63.6 l/s
	Minimum background ventilation rate (normal rate)	17.0 l/s	17.4 l/s	22.8 l/s	35.4 l/s	51.0 l/s

Purge ventilation

This term refers to ventilation provided to both habitable and wet rooms at a rapid rate on demand by the occupants. The expression 'purge' is also used in connection with overheating in buildings. Guidance on this is provided in 'Reduce overheating - a designer's guide' (CE 129) published by the Energy Saving Trust. The risk of summer overheating is assessed through **ADL1A**.

To comply with **ADF 2010** purge ventilation may be provided by mechanical means, such as extract fans, and by non-mechanical means of windows and doors. It is essential that purge ventilation is easily and efficiently controllable by occupants. Guidance on control of mechanical systems is provided in the Domestic Ventilation Compliance Guide.

Windows are often fitted with restrictors or stays that limit the openable angle for security and the prevention of accidents. It is important to ensure that the effect of these is taken into account. An override function that allows the window to be opened to a greater angle for adequate purge ventilation should be considered.

Adequate provisions for purge ventilation by windows to meet requirements of **ADF** are assessed by determining the openable window area as a proportion of the internal floor area of a room. For windows that have an openable angle of 30 degrees or more, or for parallel sliding windows/doors, the openable area of the window should be at least 1/20 of the floor area of the room. If the window has an openable angle between 15 and 30 degrees, then the openable area should be at least 1/10 of the room area. Windows that open less than 15 degrees are not suitable for providing purge ventilation. For habitable and wet rooms that either have no external walls or windows with an openable angle that is less than 15 degrees, mechanical extracts will need to be used to provide adequate purge ventilation.

In the absence of external walls to habitable and wet rooms under Systems 1 and 2, purge ventilation can be provided mechanically by installing an extract fan providing ventilation at four air changes per hour.

Mechanical provisions under Systems 3 and 4 need to be operable in 'boost' mode to increase the extract and/or supply rates to achieve adequate air changes.

What is equivalent area?

The term 'equivalent area' refers to a ventilation device's ability to deliver air through the wall or window construction or, more technically, its aerodynamic performance. Equivalent area is defined in **ADF 2010** as 'the area of a sharp-edged circular orifice which air would pass through at the same volume flow rate, under an identical pressure difference, as the opening under consideration'.

The performance varies between different types of ventilator according to the arrangement of external cowls and weatherings; the design of the flow controllers (opening and closing device); and the resistance of the pathways through which the air travels. Unfortunately it is not possible to determine the equivalent area of a ventilator just by referring to its size. This is why all devices produced for ventilation requirements should have the equivalent area stamped or printed on them.

There is a large market for ventilators that can be installed in existing windows for refurbished buildings. In **ADF 2010** Section 7, which deals with refurbishments, the requirements are for an equivalent area of 5,000 mm² to be provided for habitable rooms and 2,500 mm² for wet rooms. As a consequence there are a large number of ventilator products designed to provide an equivalent area of 2,500 mm². In works to existing buildings the BCB may simply look on site for the number of ventilators provided in each room on the basis that each ventilator is delivering 2,500 mm².

What is 1,500 mm²?

The diagram below shows the approximate areas of some familiar objects. These are not intended as a proxy for equivalent area but are merely to help visualise areas in square millimetres in more familiar terms.

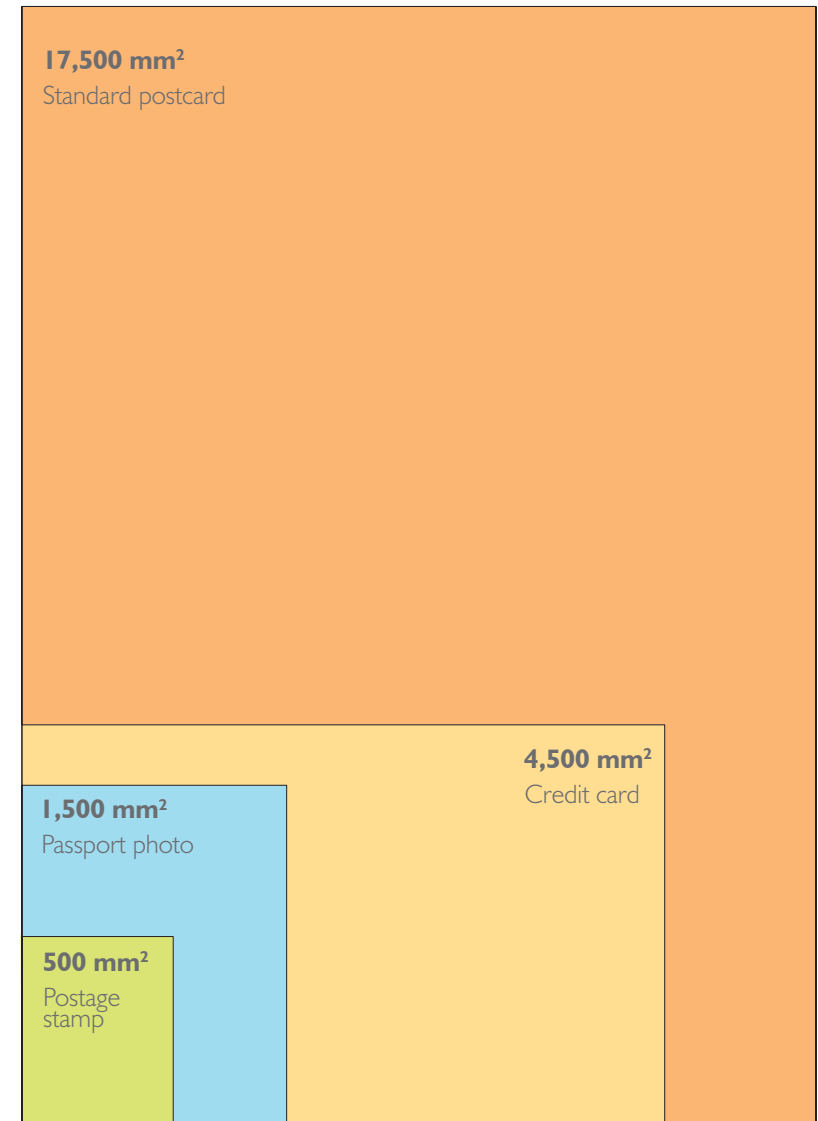

Window types

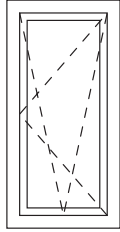

Small single window

Height	1,340 mm
Width	665 mm
Opening area	0.61 m ²
Opening type	Tilt & turn

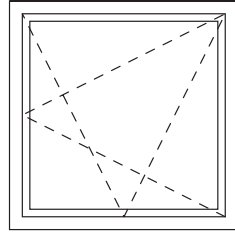

Small square window

Height	1,340 mm
Width	1,340 mm
Opening area	1.42 m ²
Opening type	Tilt & turn

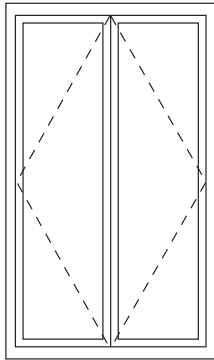

Full height window

Height	2,090 mm
Width	1,230 mm
Opening area	2.18 m ²
Opening type	Turn

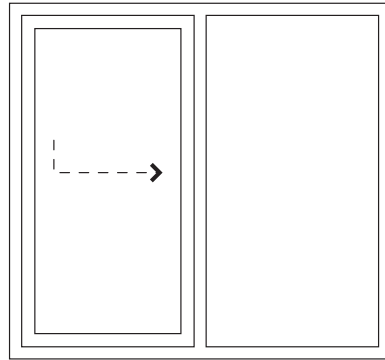

Patio door

Height	2,090 mm
Width	2,240 mm
Opening area	1.97 m ²
Opening type	Sliding

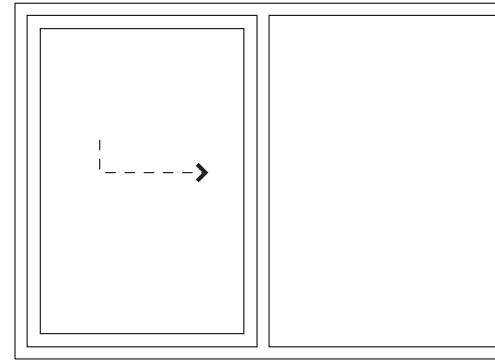

Large patio door

Height	2,090 mm
Width	2,915 mm
Opening area	2.63 m ²
Opening type	Sliding

Notes:

Five opening types have been chosen for this document, representing window types commonly found in dwellings.

The small single window and small square window have been shown mostly in utility rooms, bedrooms and bathrooms; while the full height window, patio door and large patio door have been shown in living spaces.

Tilt and turn windows have been illustrated as they allow for easier cleaning. The type of window does not impact the placement of background ventilators in the window and / or frame.

Notes:

Ventilators with three different equivalent areas were selected based on products that are widely available.

The performance of the 'in-frame' ventilator is also dependent on the dimensions of the slot cut through the frame (see tables to the right). For extruded frames (PVC and uPVC) a sleeve will often be provided through the frame as illustrated.

The 'in-frame' ventilators can also be fitted through door and window frame via the casement.

Ventilator types

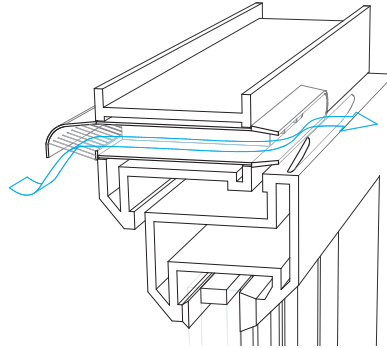

In-frame single

Typical slot width:	13 – 15 mm
Typical slot length:	230 – 300 mm
Equivalent Area (EA):	2,500 mm²

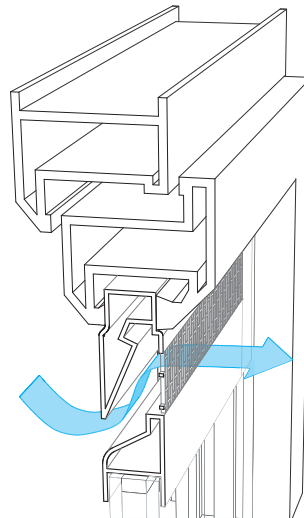

Glazed-in top

Typical slot width:	varies
Typical slot length:	glass width minus endcap width
Equivalent Area (EA):	13,500 mm² per linear metre

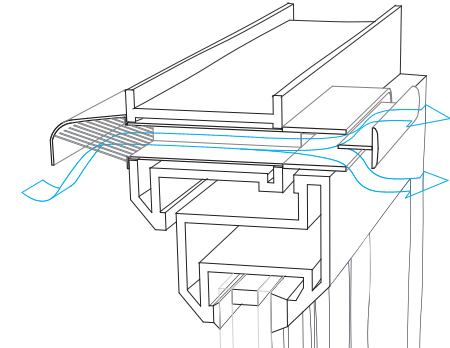

In-frame double

Typical slot width:	13 – 15 mm
Typical slot length:	2 x 175 mm
Equivalent Area (EA):	4,000 mm²

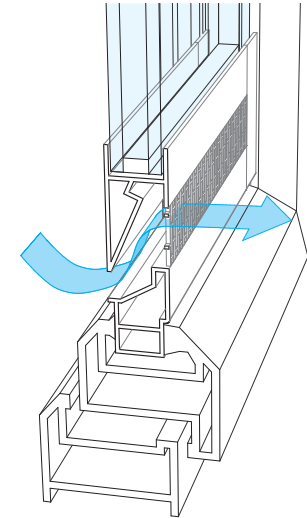

Glazed-in bottom

Typical slot width:	varies
Typical slot length:	glass width minus endcap width
Equivalent Area (EA):	13,500 mm² per linear metre

Home types

Single aspect apartment

Gross internal area	55 m ²
No. of occupants	3
No. of bedrooms	2
No. of wet rooms	2
Glazed area	9.08 m ²

The total window area is approximately 17% of the internal floor area and is distributed along a single elevation.

Schedule of window types:

Small square window:	2
Large patio door:	1

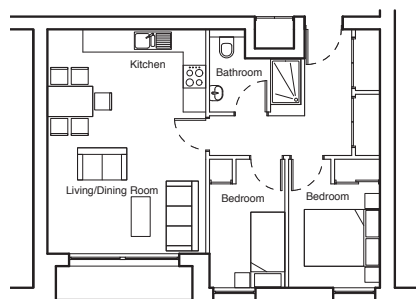

Floor plan

Dual aspect apartment

Gross internal area:	58 m ²
No. of occupants	3
No. of bedrooms	2
No. of wet rooms	2
Glazed area:	9.45 m ²

The total window area is approximately 16% of the internal floor area and is distributed across two elevations to allow for cross-ventilation.

Schedule of window types:

Small window:	2
Small square window:	2
Large patio door:	1

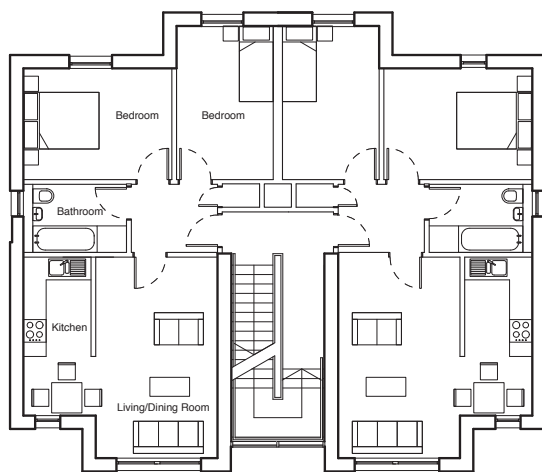

Floor plan

Mid-terrace house

Gross internal area:	76 m ²
No. of occupants	4
No. of bedrooms	3
No. of wet rooms	4
Glazed area:	10.93 m ²

The total window area is 14% of the internal floor area and is distributed across two elevations to allow for cross-ventilation.

Schedule of window types:

Small window:	1
Small square window:	5
Full height window:	1

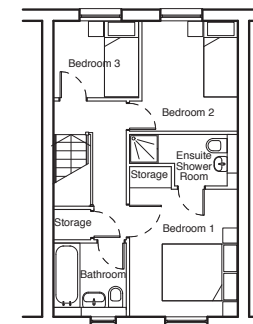

Ground floor plan

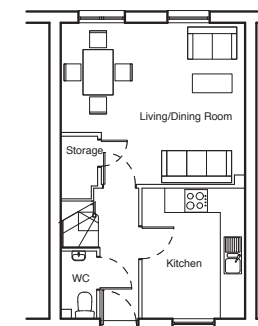

First floor plan

Detached house

Gross internal area:	118 m ²
No. of occupants	5
No. of bedrooms	4
No. of wet rooms	5
Glazed area:	32.15 m ²

The total window area is 27% of the internal floor area and is distributed across all four elevations to allow for cross-ventilation.

Schedule of window types:	
Small window:	5
Small square window:	6
Patio door:	4

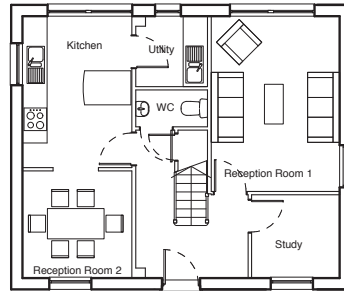

Ground floor plan

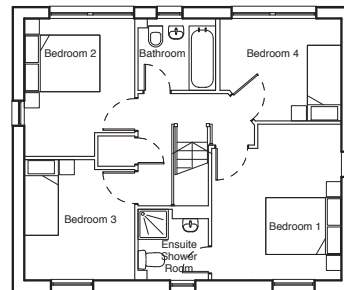

First floor plan

Large detached house

Gross internal area:	212 m ²
No. of occupants	6
No. of bedrooms	5
No. of wet rooms	6
Glazed area:	36.55 m ²

The total window area is 27% of the internal floor area and is distributed across all four elevations to allow for cross-ventilation.

Schedule of window types:	
Small window:	2
Small square window:	18
Patio door:	2

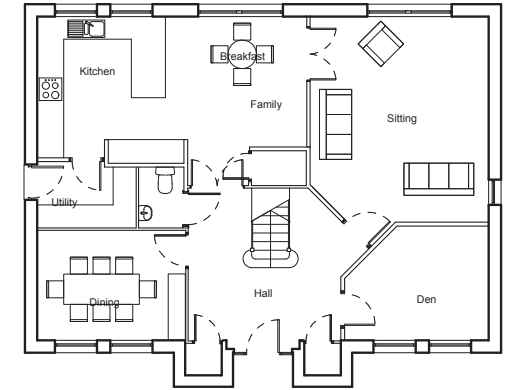

Ground floor plan

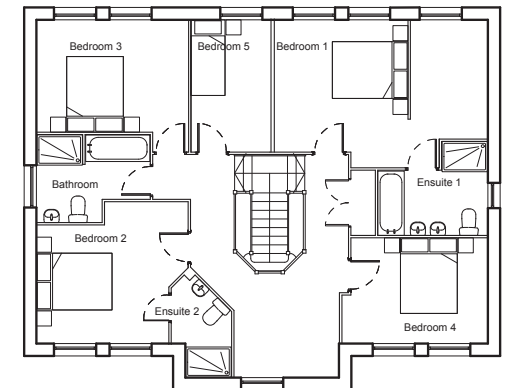

First floor plan

Looking forward

There are a number of factors that will influence the choice of ventilation system for a new home, but decisions in the future are likely to be made on the basis of both the ventilation performance and the energy saving potential of the strategy. Designers aiming for higher levels of the Code for Sustainable Homes are increasingly specifying MVHR systems (System 4) because of their benefits in SAP (the Standard Assessment Procedure) which then translate to higher scores in the energy section (Ene 1) of the Code. However, for the occupant to benefit from these savings the systems must be installed and commissioned in a way that produces an 'as built' performance that matches the predictions of the SAP model.

There is widespread concern regarding the potential problems with whole house ventilation systems based on evidence that systems are not always installed, commissioned or operated correctly. Problems will arise for example where too much flexible ductwork has been used, ventilation units have been wired incorrectly, sufficient space for access for maintenance has not been allowed or the system has not been properly commissioned. The ventilation industry has responded positively to the new regulations, which are seen to address many of these concerns.

However, it will take time for the industry to develop the skills needed to design, install and commission ventilation equipment correctly. This is especially true for smaller builders who in the past have generally relied on an electrician or a plumber to install the building services. Smaller builders will need to think in advance about who will be installing ductwork and commissioning ventilation systems. They will also need to plan for the duct routes and the space necessary for their installation. There are a good number of recommendations in the Domestic Ventilation Compliance Guide that address planning, design and co-ordination as well as commissioning.

On site whoever installs the ductwork will need to understand the knock-on effects of ad-hoc decisions made, for instance, reducing a duct size to negotiate a smaller than expected void or substituting flexible ductwork to make life easier in a restricted area. Ductwork is not always installed by a dedicated ventilation engineer so the principles of good practice installation need to be communicated to a wider portion of the industry. In the future, ad-hoc decisions made on site should diminish by careful co-ordination of the ventilation system and the dwelling design. It is advisable for the designer to allow for the incorporation of the ventilation system and its space requirements. Schemes to recognise 'competent persons' will no doubt also come forward.

ADF 2010 is designed to provide robust ventilation for the increasingly airtight homes that are being built now and for the zero carbon homes of the future, and it is not expected that there will be amendments in the 2013 revision of the Building Regulations. The challenge for the industry therefore is to develop its own guidance, education, training and quality assurance schemes to deliver the intended performance to the occupiers of these increasingly complex homes.

Glossary

Air permeability

This is the physical property used to measure the airtightness of the building fabric. It is defined as air leakage rate per hour per square metre of envelope area at a test reference pressure difference across the building envelope of 50 Pascals. It is given the units of $\text{m}^3/(\text{h}\cdot\text{m}^2)$ @ 50 Pa.

Airtightness

This is the descriptive term for the resistance of the building envelope to infiltration with ventilators closed. The greater the airtightness the lower the infiltration.

Background ventilator

This is a small ventilation opening designed to provide controllable whole building ventilation.

Boost function

This is a control setting in systems that feature continuous mechanical extract such as in Systems 3 and 4. It enables an increase in the rate of mechanical extract of air for the purpose of purge ventilation which may be either manually or automatically controlled.

Continuous operation

This is when a mechanical device runs all the time as under Systems 3 and 4. The mechanical system would operate at a constant rate with additional provisions for manually or automatically controlled 'boost extraction' for purge ventilation.

Cross-ventilation

This can be achieved if a dwelling has more than one external façade and if the required equivalent area of background ventilation can be distributed across opposite or adjacent façades.

According to **ADF 2010** this type of ventilation is possible if no more than 70% of background ventilation is provided on a single façade.

Enhanced single sided ventilation

This is a method of providing natural ventilation in a dwelling where more than 70% of the required equivalent area of background ventilation must be provided on one exposed façade. Ventilation openings at both the top and bottom of a window enable better movement of air. Special care must be taken when positioning the lower opening to prevent cold draughts during winter.

Extract ventilation

This is the removal of air directly from a space to outside and may be provided by either natural or mechanical means.

Free area

This is the area that is cut out of the frame into which the ventilator is fitted.

Habitable room

A room in a home that is used for dwelling purposes but which is not solely a kitchen, utility room, bathroom, cellar or sanitary accommodation.

Infiltration

This is the uncontrolled exchange of air between the inside of a building and the outside through cracks, poor seals and other unintentional openings in a building.

Intermittent fans

Mechanical fans that are operated on demand for the purpose of removing pollutants or water vapour. These fans may be either manually or automatically controlled.

Purpose provided ventilation

That part of the ventilation of a building provided by mechanical and non-mechanical ventilation devices designed into the building.

Sanitary accommodation

This is a space in a dwelling containing a water closet (WC).

Stack effect

This is the movement of air due to natural convection that will occur causing warm air to flow from lower to upper levels in a room or building.

Trickle ventilator

A type of background ventilator that is installed in either the sash or frame of a window or door (known as a slot ventilator) or within the glazed area (known as a glazed-in ventilator).

Ventilation opening

A purpose-provided opening leading directly to external air; such as openable sections of a window, door, louvre or a background ventilator.

Wet room

A room used for domestic activities such as clothes washing, bathing and cooking, which give rise to significant amounts of moisture in the space. This type of room includes a kitchen, bathroom, sanitary accommodation or utility room.

Whole dwelling ventilation

Usually steady continuous ventilation of rooms or spaces at a low rate to dilute and remove pollutants and water vapour as well as supplying outdoor air into the building. The provisions for this type of ventilation are in addition to those for extract ventilation and purge ventilation.

Part F 2010 – where to start:

An introduction for house builders and designers

This NHBC Foundation guide is intended to give house builders and designers a broad understanding of the changes to the specifications that will need to be incorporated as the starting point for detailed design. The guide provides examples of typical home types outlining possible approaches to the four ventilation systems to comply with **ADF 2010** and addresses installation and commissioning requirements outlined in the Domestic Ventilation Compliance Guide 2010.

Published by Richards Partington Architects on behalf of NHBC Foundation
November 2011
NF 37
ISBN 978-0-9568415-3-7

NHBC *F* **FOUNDATION**
Housing research in partnership with BRE Trust